

DIFFERENTIAL
RANGE

 **SPO3**
DIFFERENTIAL



SADEV[®]
RACING TRANSMISSION

SADEV
RACING TRANSMISSION

DIFFERENTIAL RANGE

SPO3 DIFFERENTIAL

Used for many applications, ranging from ice to circuit racing, the **SPO3** differential is a resolutely versatile and reliable product that can be positioned at the front or rear of the vehicle. Offering a wide choice of possible configurations, it adapts easily to your needs.



APPLICATIONS

- › Circuit
- › Hill Climb
- › Ice Racing
- › Drift
- › Rallycross
- › Rally



TECHNICAL SPECS

Bevel gear ratio : 8x31, 10x29 or 10x33

The bevel gear is cut and grinded in house on our CNC units

High strength carburizing steel

Shot penning on internal parts

Limited slip differential (low friction optional)

Removable differential cartridge (optional)

Preload made by spring washer

Anti-friction coating on odd discs

Anti wear steel flat discs

Wide range of ramp plates available

Splash lubrication system

Magnetic drain plugs

Painted AS7G aluminum casings

Assembled with spacers and studs

Casing joint faces sealed with O'rings

3 assembly possible :

- Centered
- Offset on crown wheel side
- Offset on opposite side of the crown wheel

Weight : 27 Kg - 59 lbs

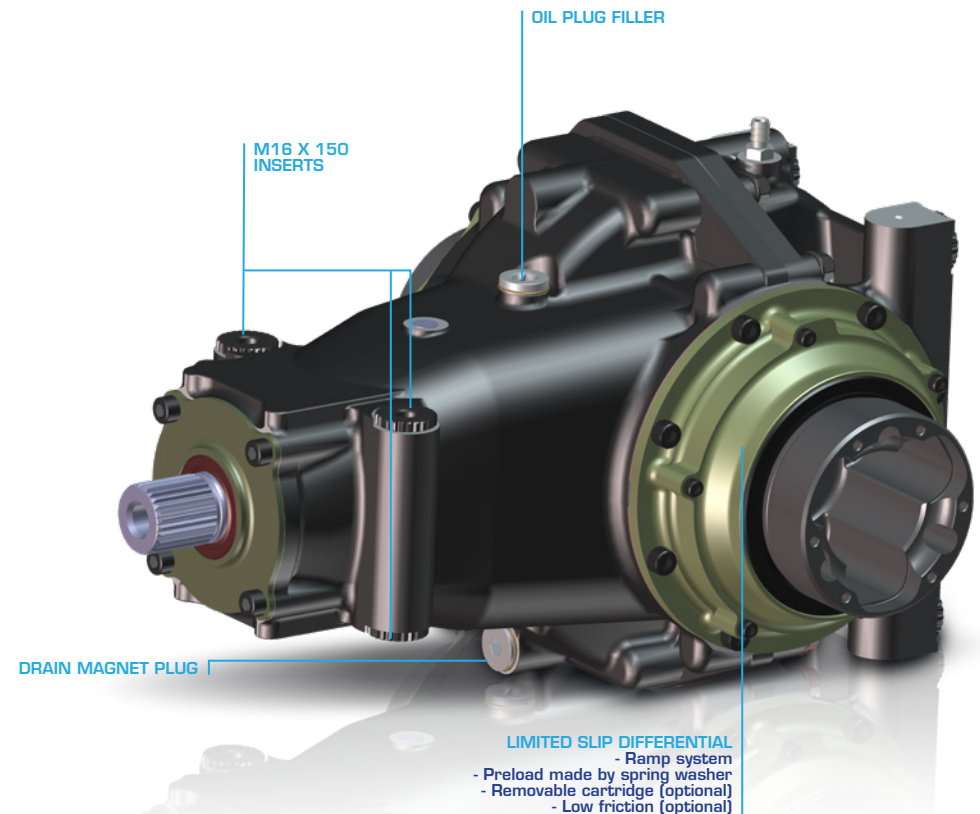
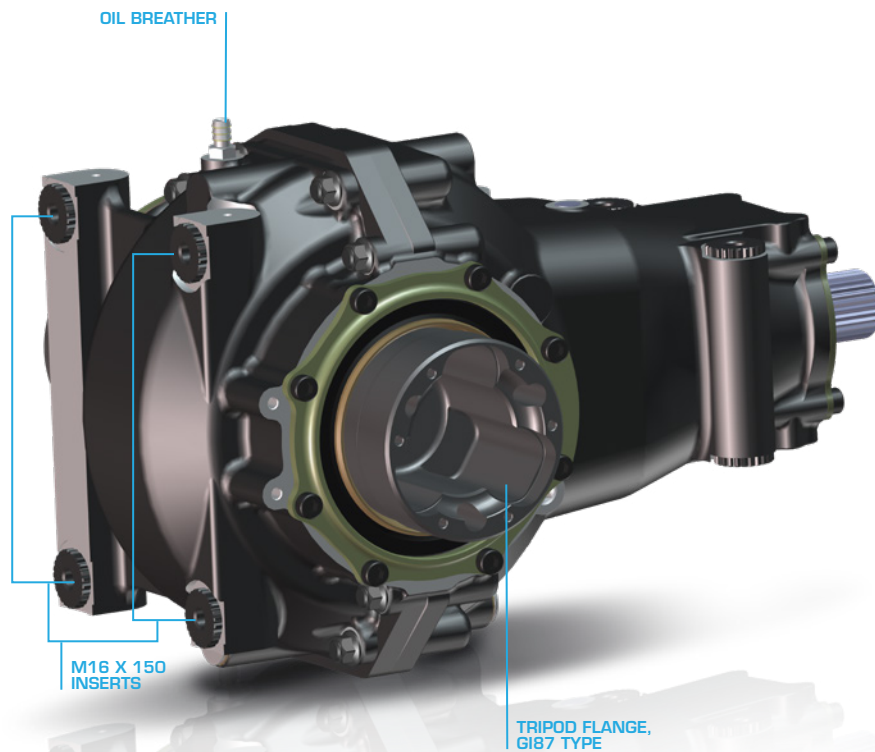

ACCESSORIES

- › Drive shafts
- › Propshaft

LOW FRICTION LIMITED SLIP DIFFERENTIAL (OPTIONAL)

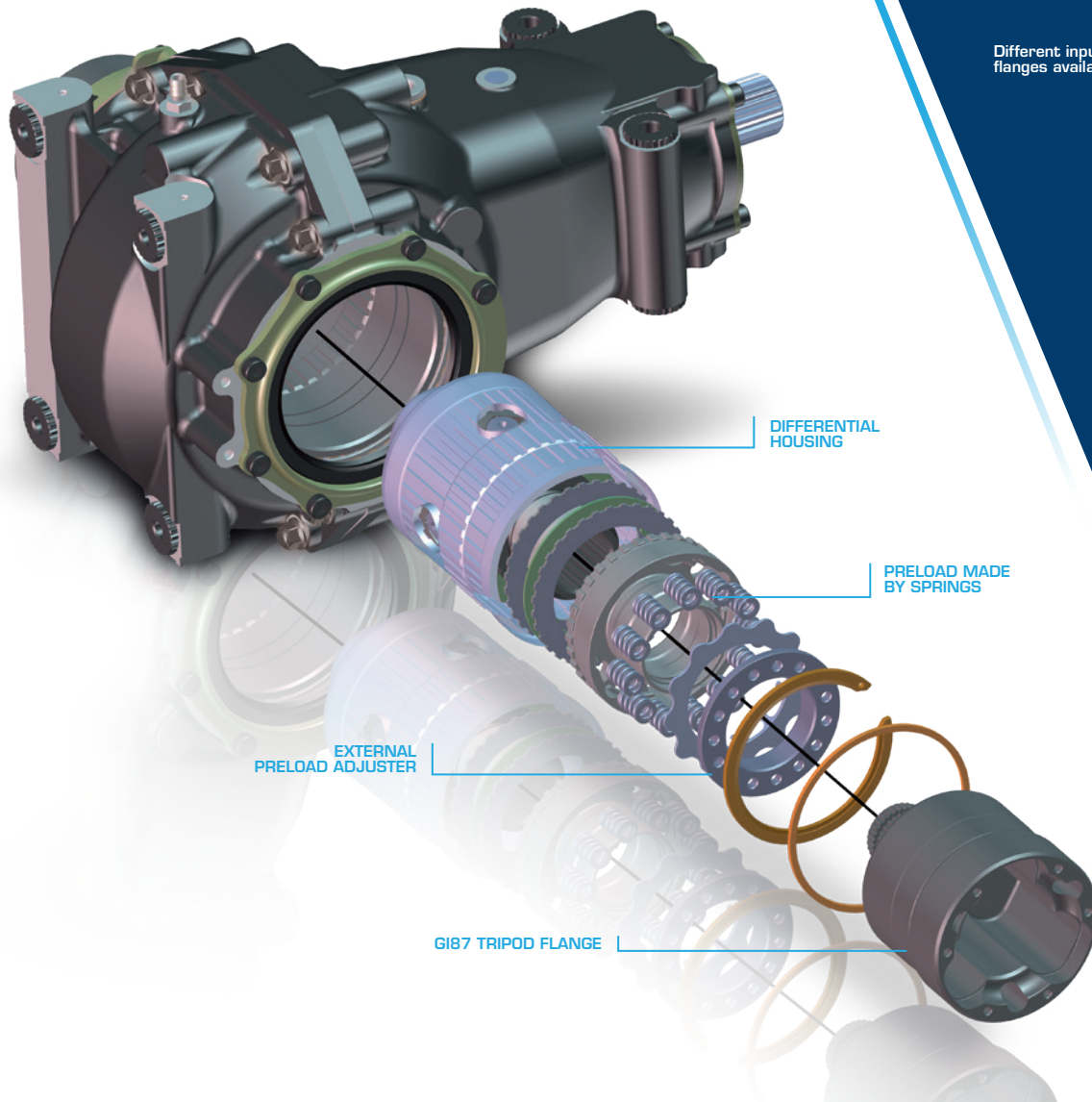

DIFFERENT CONFIGURATIONS

Different input flanges available.

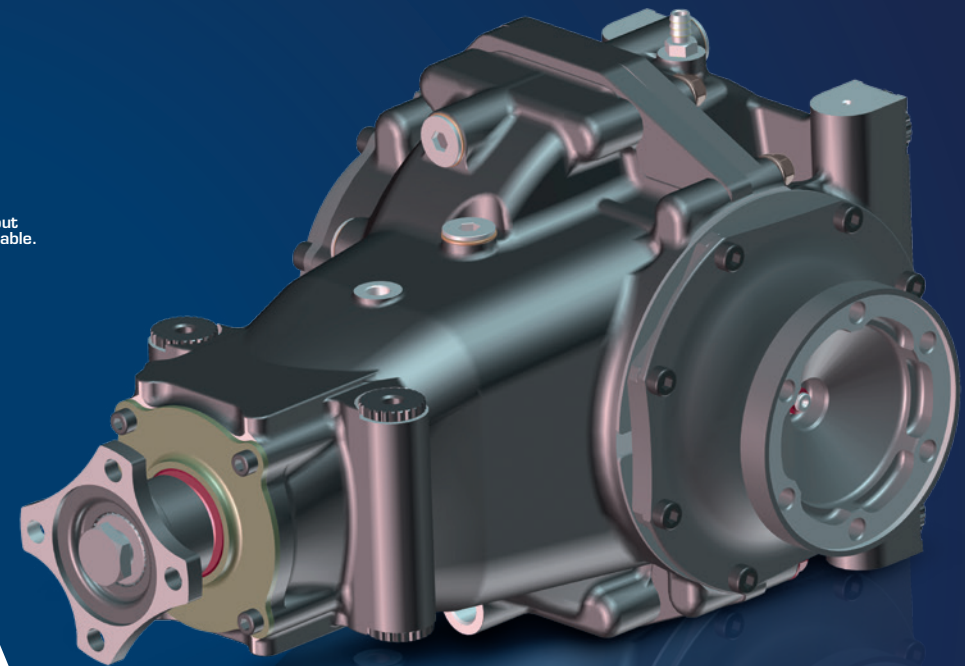

G187 driven tripod flange or 108mm Lobro flange are available



SPO3 DIFFERENTIAL

- › **Reliability:** The **SPO3** is the best-selling differential in the Supercar Rallycross category. Its reliability makes it a must-have product.
- › **Robustness:** Our finite element calculation tool enables us to design extremely strong, compact, lightweight casings to meet the needs of rallycross.
- › **Dimensions:** The compact size of the **SPO3** makes it easy to fit in your vehicle.
- › **Flexibility:** The **SPO3** differential can be fitted at the front or the rear in both 2 and 4 wheel drive chassis.
- › **Limited slip self-locking ramp differential:** The **SPO3** differential offers the possibility of integrating an optimised teeth version (available as an option).

MAXIMUM ENGINE TORQUE

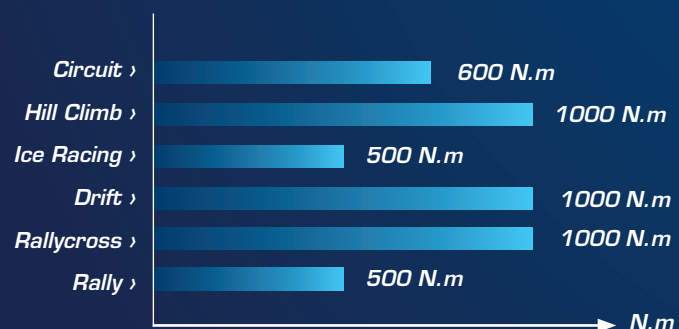



ONE PASSION: VICTORY

SADEV has an exceptional record in supplying unique engineering to the most prestigious drivers and manufacturers. SADEV's products stand out for their technology, their excellence and their ambition. As precise as they are reliable, these high-tech masterpieces are the key to your victory. SADEV has just one goal: to make sure you win.

FOLLOW US



WWW.SADEV-TM.COM

6, rue Grand'Montains - 85110 SAINT-PROUANT - FRANCE

Tel: +33 (0)2 51 66 42 68

sadev@sadev-tm.com



A TEAM AT YOUR SIDE

FRANCE	SADEV FRANCE - sadev@sadev-tm.com
USA	SADEV TRANSMISSIONS, INC. - info.usa@sadev-tm.com
UK	SWR MOTORSPORT LTD - serviceswrmotorsport@gmail.com
ITALY	GIEFFE RACING - info@giefferacing.com
SPAIN	DE LA PUENTE MOTORSPORT - dlpmotorsport@movistar.es
NETHERLANDS	RACING DEVELOPMENT - info@racingdevelopment.nl
NETHERLANDS	PETERS AUTOSPORT - bart@petersautosport.nl
BELGIUM	R TEC - info@rtec.ws
CZECH REPUBLIC	SADAC - info@sadac.cz
GERMANY	MTO ENGINEERING - info@mtoengineering.com
SWEDEN	HANSEN MOTORSPORT - kenneth@hansen-motorsport.se
DENMARK	GUNNAR AASKOV MOTORSPORT - mail@aaaskov-motorsport.dk
FINLAND	SET PROMOTION - kalle.pinomaki@setpromotion.com
SWITZERLAND	CHRISTIAN FERRARI - ferrach@bluewin.ch
SOUTH AFRICA	CENTURY RACING - julien@centuryracing.co.za
ARGENTINA	JPO RACING - racingjpo@gmail.com
BRAZIL	CD MOTORSPORT ENGINEERING - sadev.brasil@gmail.com

